

Royal Palm Beach

Class I Injection Facility No. 43

ENGINEERING REPORT
ON THE
DRILLING AND TESTING
OF THE INJECTION AND DUAL-ZONE MONITOR WELL
FOR THE VILLAGE OF ROYAL PALM BEACH

Prepared for
CRAIG A. SMITH AND ASSOCIATES
POMPANO BEACH, FLORIDA

Prepared by
CH2M HILL
800 Fairway Drive
Suite 350
Deerfield, Beach, Florida 33441

August 1988

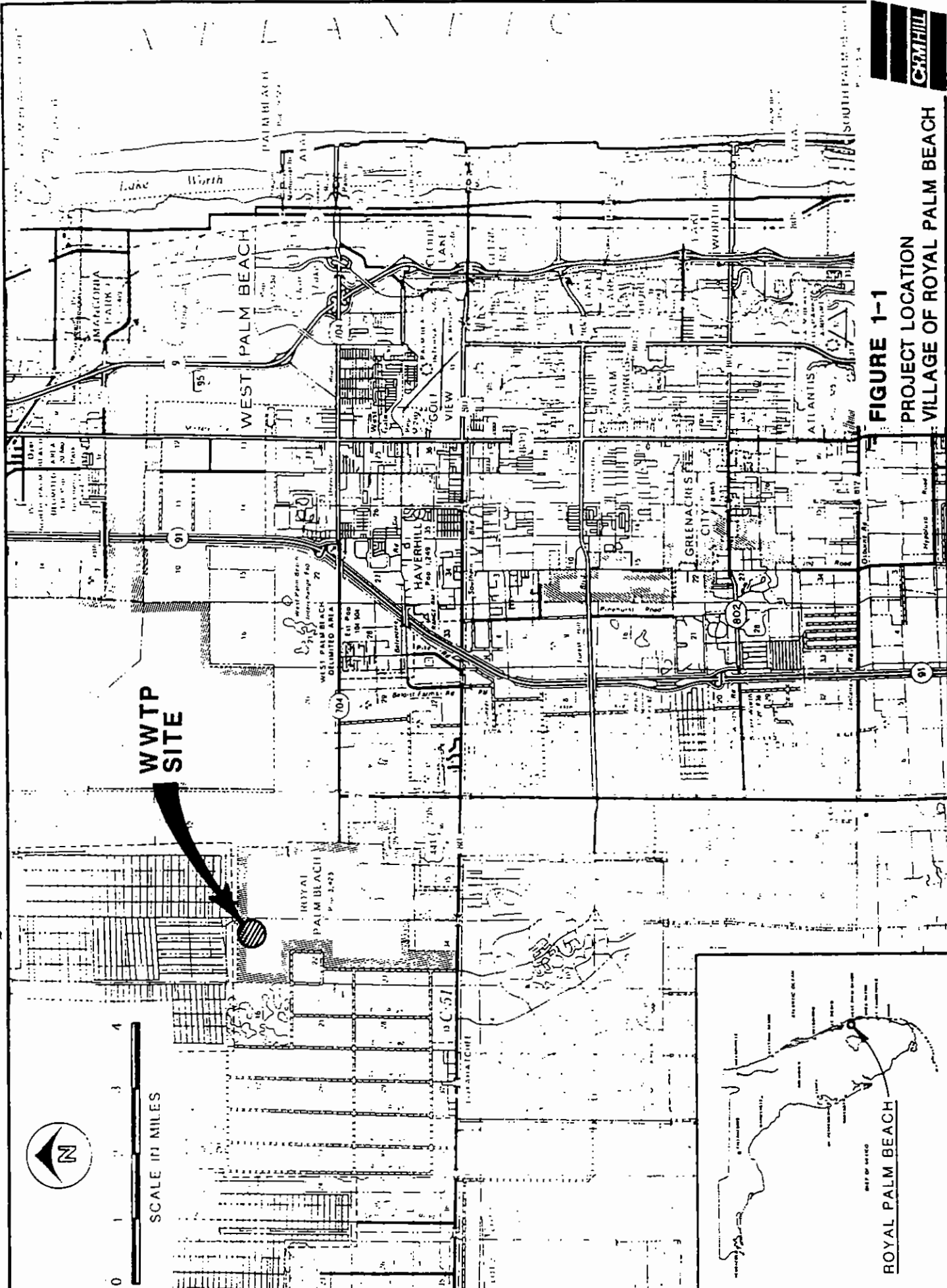

FIGURE 1-1

PROJECT LOCATION
VILLAGE OF ROYAL PALM BEACH



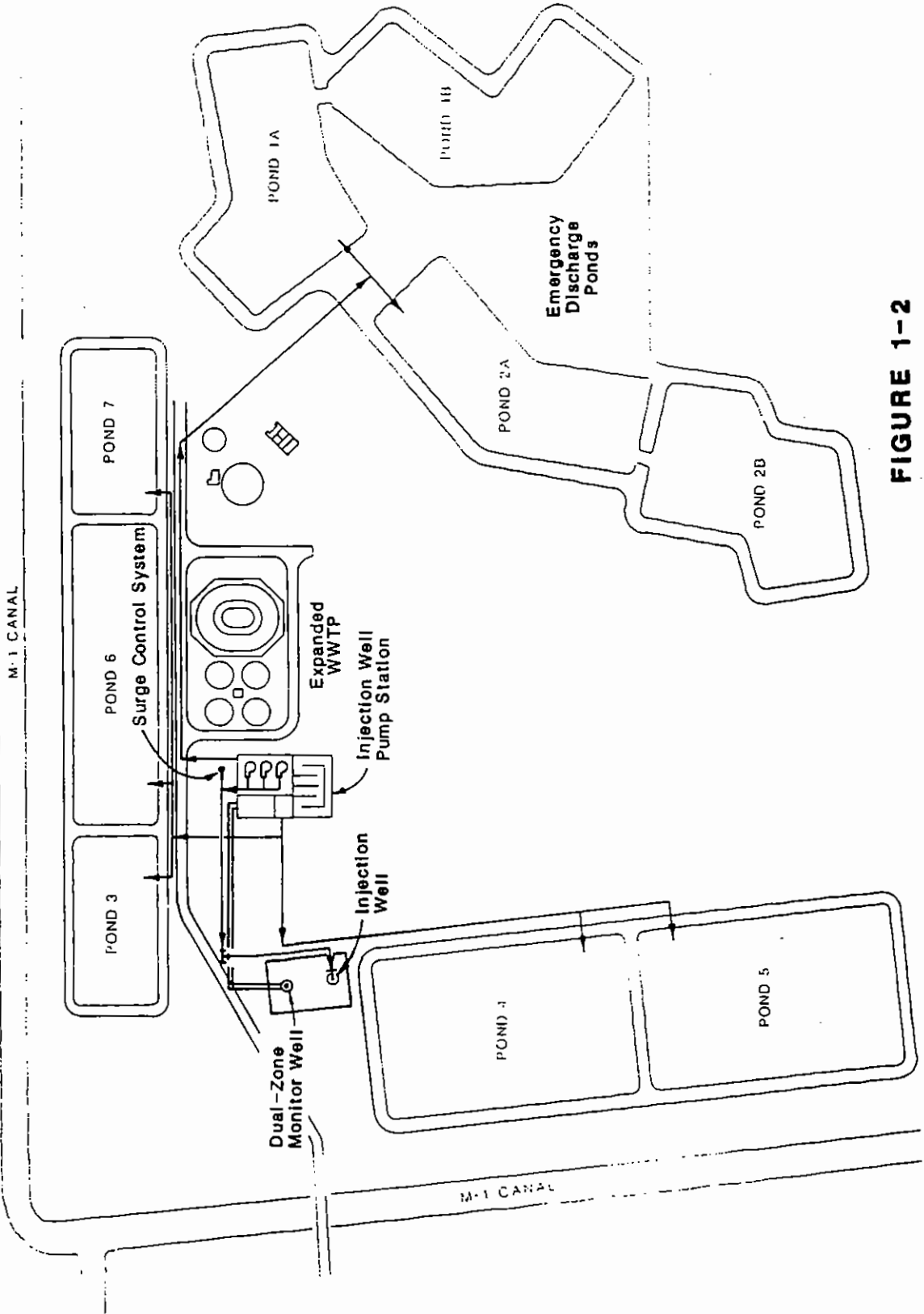
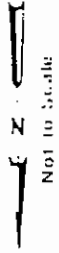

FIGURE 1-2
WASTEWATER TREATMENT PLANT SITE PLAN
AT THE VILLAGE OF ROYAL PALM BEACH

C-1156.A0

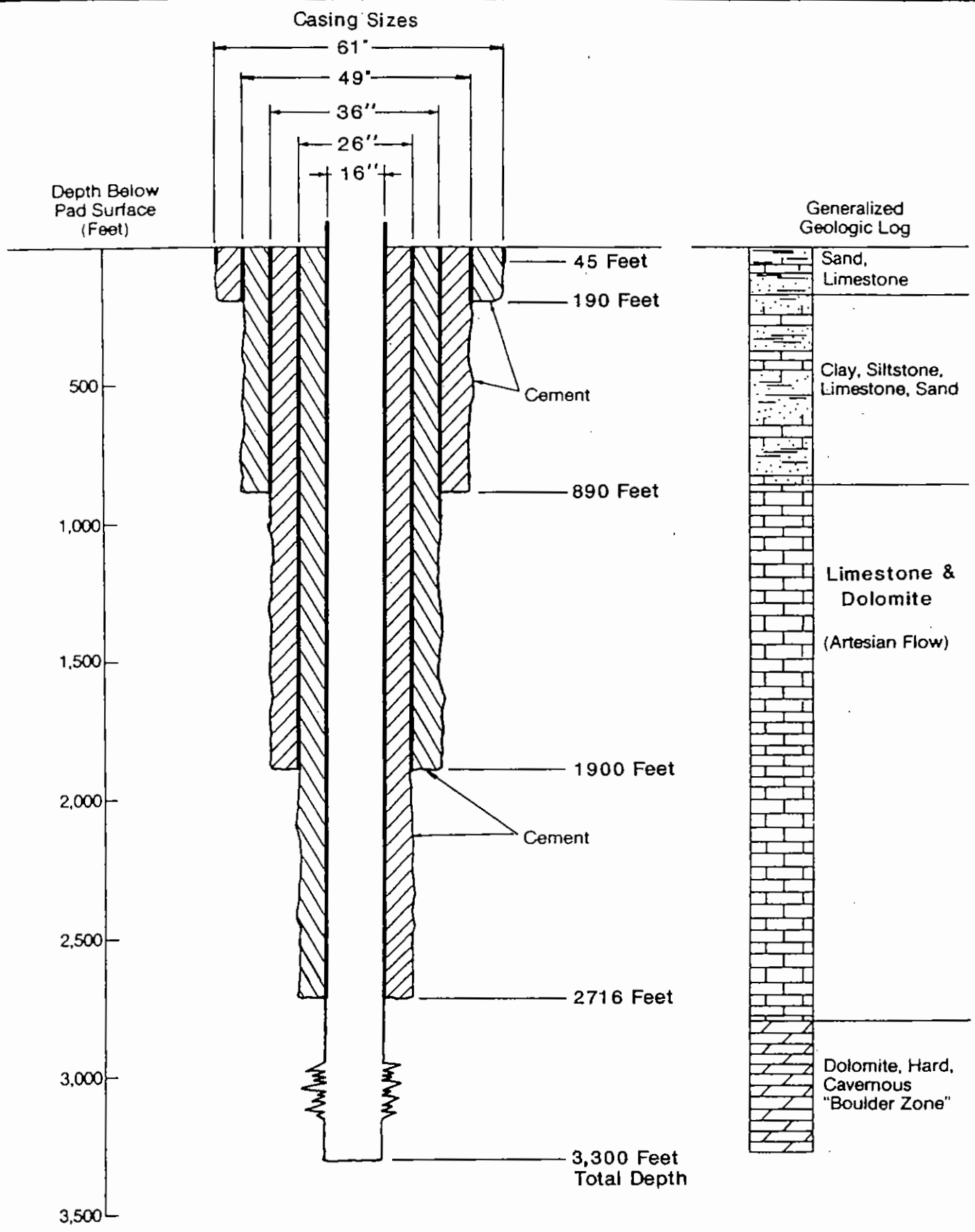

FIGURE 2-2

INJECTION WELL COMPLETION DIAGRAM
AT THE VILLAGE OF ROYAL PALM BEACH



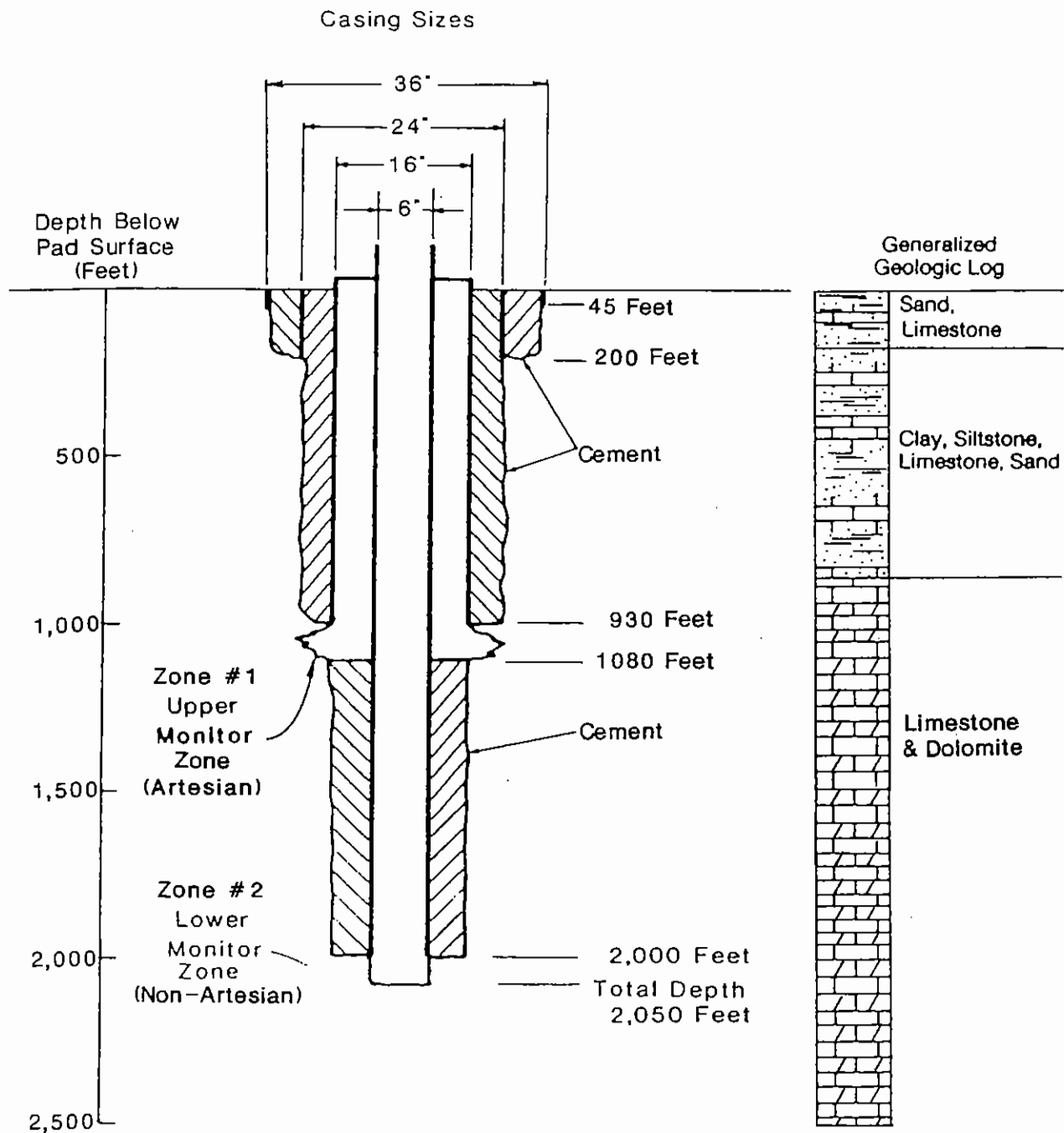
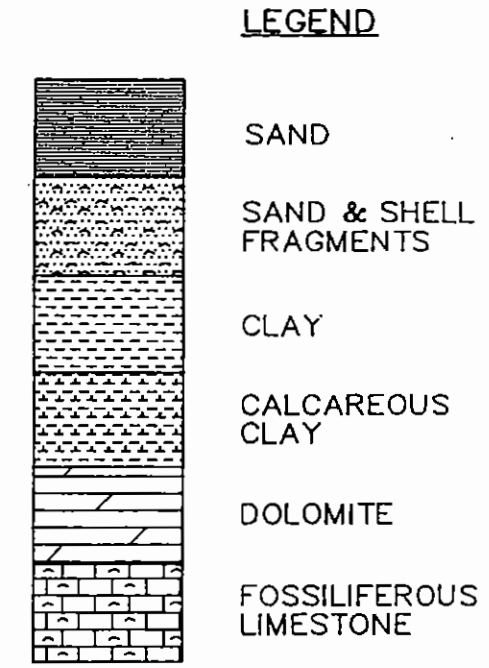
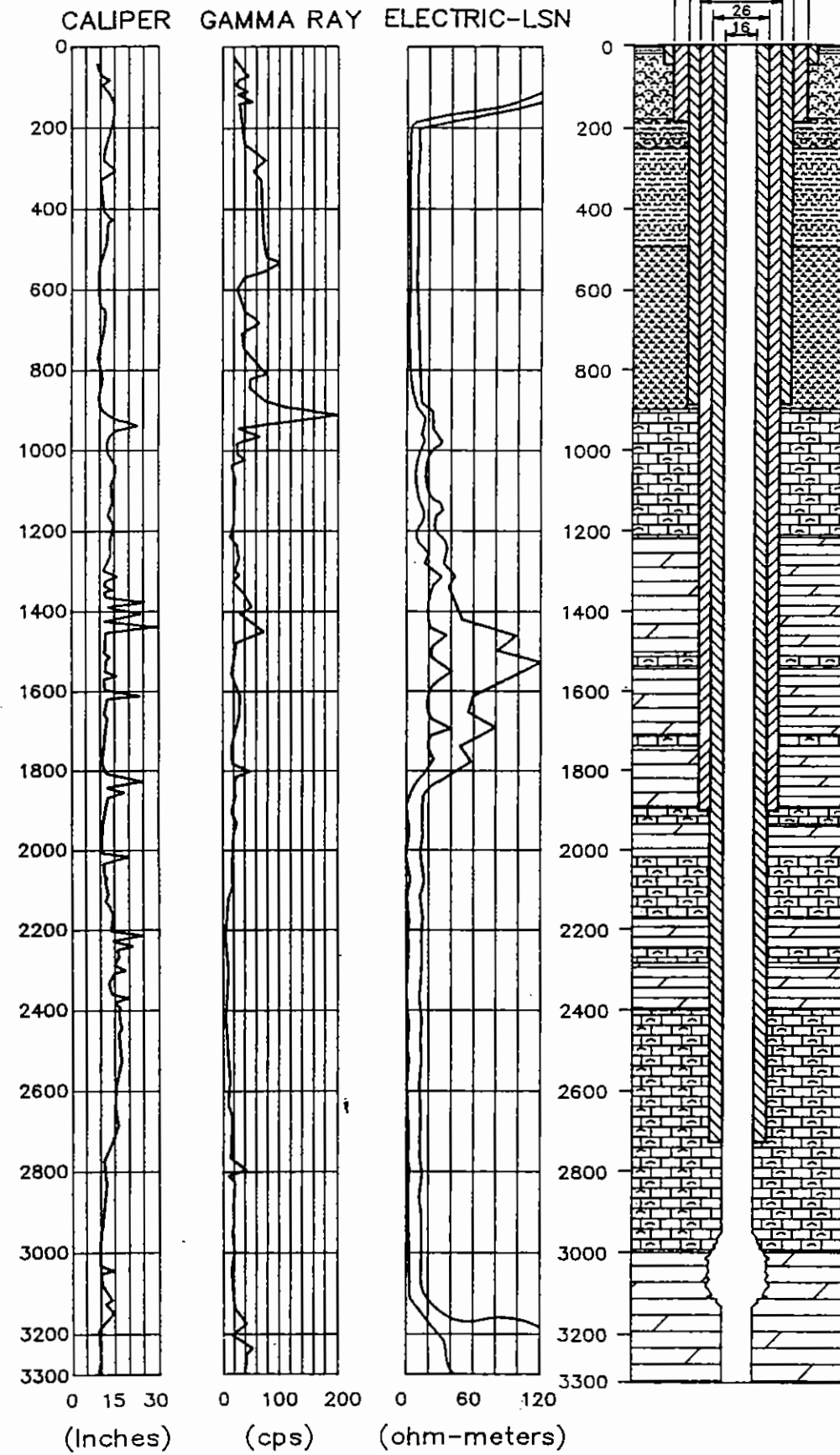

FIGURE 2-4
DUAL-ZONE MONITOR WELL
COMPLETION DIAGRAM AT THE
VILLAGE OF ROYAL PALM BEACH



LITHOLOGIC DESCRIPTION	GEOLOGIC AGE	FORMATION NAME		
Shell, Sand, Calcareously Cemented Sandstone	Pleistocene	Pamlico Sand Anastasia	Surficial Aquifer	
Sandy Clay with Shell	Pliocene	Tamiami		
Dark Green Clay with Shells Fragments	Miocene	Hawthorne	Confining Units	
Calcareous Clay, Phosphatic		Tampa Limestone		
Fossiliferous Arenaceous Limestone, Yellowish Gray, Fine Crystallization	Oligocene	Suwannee Limestone	FLORIDAN AQUIFER SYSTEM	
Grayish Orange Limestone, Fine Crystallization Dolomite, Dark Brown, Vuggy	Upper Eocene	Avon Park Limestone		
Dolomite, Brown, Medium Crystalline Sucrosic		Lake City Limestone		
Interbedded Limestone; Dolomite Dark Yellowish Brown	Mid Eocene	Oldsmar Limestone		
Dolomite, Yellowish Brown Medium Grain Intercrystalline Porosity				
Limestone, Pale Orange, Fossiliferous, Calcilitite, Dictyonus Americanus	Lower Eocene			
Dolomite, Dark Yellowish Brown, Intercrystalline Porosity, Interbedded Limestone				
Dolomite, Dark Yellowish Brown, Sucrosic Texture				High Permeability (Boulder Zone)



NOTE
 cps Counts per Second
 LSN Long-Short Normal Electric Resistivity

FIGURE 3-1
 GENERALIZED SUBSURFACE DATA FOR THE INJECTION WELL AT THE VILLAGE OF ROYAL PALM BEACH

